

HGL100-12A

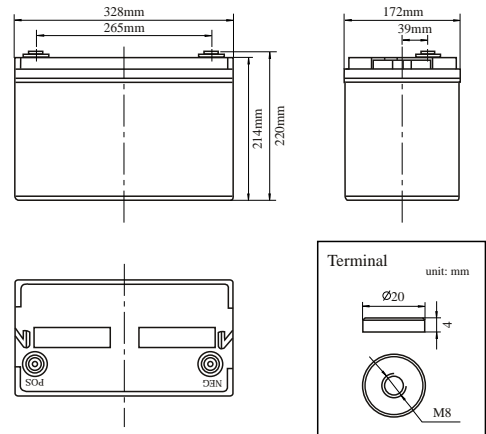

Specifications

Nominal Voltage		12V
Rated Capacity(20 hour rate)		100AH
Dimension	Total Height (with terminals)	220mm(8.66inches)
	Height	214mm(8.43inches)
	Length	328mm(12.91inches)
	Width	172mm(6.77inches)
Weight		Approx.34.2kg(75.40lbs)

Characteristics

Capacity 77°F (25°C)	20 hour rate (5A)	100AH
	10 hour rate (9.3A)	93AH
	5 hour rate (17A)	85AH
	1 hour rate (60A)	60AH
	15 min rate (175A)	43.75AH
Internal Resistance	Full charged Battery 77°F (25°C)	3.5mΩ
Capacity affected by Temperature (20 hour rate)	104°F (40°C)	102%
	77°F (25°C)	100%
	32°F (0°C)	85%
	5°F (-15°C)	65%
Self-Discharge 77°F(25°C)	Capacity after 3 month storage	91%
	Capacity after 6 month storage	82%
	Capacity after 12 month storage	64%
Max. Discharge Current 77°F(25°C)	1500A (5S)	
Terminal	Standard	F17
	Optional	
Charging (Constant Voltage)	Cycle	Initial Charging Current 20A Or Small 14.5V~14.9V/77°F (25°C)
	Float	13.6V~13.8V/77°F (25°C)

Discharge characteristics 77°F(25°C)

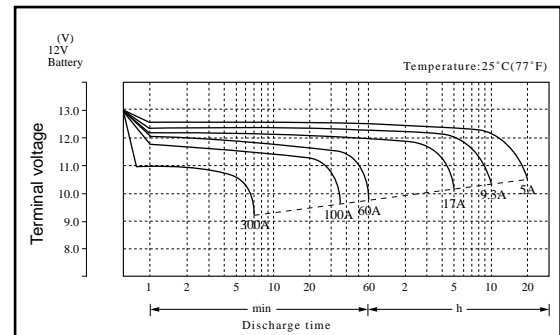

Duration of discharge vs. Discharge current

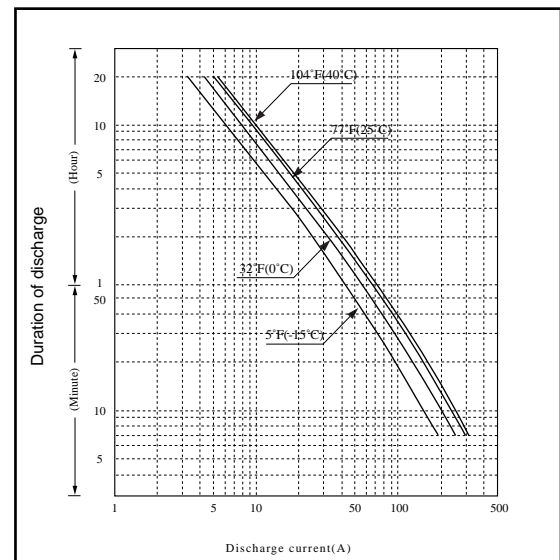

Constant Power Discharge Watts Per Cell @ 77°F(25°C)

Cut off voltage V/cell	5M	10M	15M	30M	45M	1H	2H	3H	5H	8H	10H	12H	24H
1.60	668	488	390	235	168	129	75.2	52.4	35.2	23.2	19.6	16.9	8.70
1.65	655	483	385	233	166	128	74.8	52.0	35.2	23.2	19.6	16.9	8.70
1.67	647	478	380	231	165	127	74.4	51.6	35.2	23.2	19.6	16.9	8.70
1.70	626	462	365	225	161	126	74.1	51.2	35.2	23.2	19.6	16.9	8.70
1.75	598	442	349	216	157	124	73.5	50.6	34.7	22.8	19.4	16.9	8.70
1.80	570	422	333	207	153	122	72.8	50.0	34.2	22.4	19.0	16.6	8.70

Note The above data are average values, and can be obtained within 3 charge/discharge cycles. These are not minimum values.